

THIS MANUAL IS AN ONLINE BACKUP TO YOUR
ORIGINAL HARDCOPY VERSION.

RX7CITY.COM ASSUMES NO RESPONSIBILITY IN HOW YOU USE
THIS MANUAL. THIS MANUAL IS FOR EXPERIENCED MECHANICS
AND IS TO BE USED AT YOUR OWN RISK!



WHEELS AND TIRES

OUTLINE Q - 2
 SPECIFICATIONS Q - 2
TROUBLESHOOTING GUIDE Q - 2
WHEELS AND TIRES Q - 3
 SPECIAL NOTES ABOUT WHEELS
 AND TIRES Q - 3
 NOTES REGARDING TIRE
 REPLACEMENT Q - 3
 INSPECTION/ADJUSTMENT Q - 3
 REMOVAL/INSTALLATION Q - 4
 TIRE ROTATION Q - 5
 WHEEL BALANCE ADJUSTMENT Q - 5

29U0QX-001



Q

OUTLINE , TROUBLESHOOTING GUIDE

OUTLINE

SPECIFICATIONS

Item	Type	Standard	Temporary spare
Wheel	Size	16 × 8JJ	16 × 4T
	Offset	50 {1.97}	40 {1.57}
	Pitch circle diameter	mm {in}	114.3 (4.50)
	Material	Aluminum alloy	
Tire	Size	P225/50R16 91V P225/50 ZR 16	T135/70D16
	Air pressure	kPa {kgf/cm ² , psi}	220 {2.2, 32}
			415 {4.2, 60}

37U00X-001

TROUBLESHOOTING GUIDE

Problem	Possible cause	Action	Page
Excessive or Irregular tire wear	Refer to page Q-4 for details.		
Premature tire wear	Incorrect tire pressure	Adjust	Q-3
Tire squeal	Incorrect tire pressure Tire deterioration	Adjust Replace	Q-3 -
Road noise or body vibration	Insufficient tire pressure Unbalanced wheel Deformed wheel or tire Irregular tire wear	Adjust Adjust Repair or replace Replace	Q-3 Q-5 - -
Shake (steering wheel vibrates up/down)	Excessive tire or wheel runout Loose lug nuts Unbalanced wheel Cracked or worn engine mount rubber Cracked or worn transmission mount rubber	Replace Tighten Adjust or replace Replace Replace	- Q-4 Q-5 Section C Section J,K
Shimmy (steering wheel vibrates left/right)	Cracked or worn steering gear mount rubber Loose steering gear mounting bolts Stuck or damaged steering ball joint Excessive tire or wheel runout Loose lug nuts Unbalanced wheel Insufficient tire pressure Unevenly worn tires Malfunction of shock absorber Loose shock absorber mounting bolts Stuck or damaged lower arm ball joint Cracked or worn suspension bushings Damaged or worn front wheel bearing Improperly adjusted front wheel alignment	Replace Tighten Replace Replace Tighten Adjust or replace Adjust Replace Replace Tighten Replace Replace Replace Replace Adjust	Section N Section N Section N - Q-4 Q-5 Q-3 - Section R Section R Section R Section R Section M Section R
Uneven (one-sided) braking	Unequal tire pressures	Adjust	Q-3
Steering wheel doesn't return properly or pulls left or right	Incorrect tire pressure Irregular tire wear (left/right) Unequal tire pressures Different types or brands of tires mixed (left/right) Loose lug nuts	Adjust Replace Adjust Replace Tighten	Q-3 - Q-3 - Q-4
General driving instability	Unequal tire pressures Damaged or unbalanced wheel Loose lug nuts	Adjust Replace or adjust Tighten	Q-3 Q-5 Q-4
Excessive steering wheel play	Loose lug nuts	Tighten	Q-4

37U00X-002

WHEELS AND TIRES

SPECIAL NOTES ABOUT WHEELS AND TIRES

1. Do not use wheels or tires other than the specified types.
2. Aluminum wheels are easily scratched. When washing them, use a soft cloth, never a wire brush. If the vehicle is steam cleaned, do not allow boiling water to contact the wheels.
3. If alkaline compounds (such as salt-water or road salts) get on aluminum wheels, wash them as soon as possible to prevent damage. Use only a neutral detergent.

29U0QX-004

NOTES REGARDING TIRE REPLACEMENT

Note the following points when tires are to be removed from or mounted onto the wheels.

1. Be careful not to damage the tire bead, the rim bead, or the edge of the rim.
2. Apply a soapy solution to the tire bead and the edge of the rim.
3. Use a wire brush, sandpaper, or cloth to clean and remove all rust and dirt from the rim edge and the rim bead. For aluminum wheels, use only a cloth for this purpose; never use a wire brush or sandpaper.
4. Remove pebbles, glass, nails, and other foreign items embedded in the tire tread.
5. Be sure the air valve is installed correctly.
6. After mounting a tire onto a wheel, inflate it to 250–300 kPa {2.5–3.0 kgf/cm², 36–42 psi}. Verify that the bead is seated correctly onto the rim and that there are no air leaks. Then reduce the pressure to the specified level.
7. If a tire iron is used to change a tire on an aluminum wheel, be sure to use a piece of rubber between the iron lever and the wheel to avoid damage to the wheel. Work should be done on a rubber mat, not on a hard or rough surface.

37U0QX-003

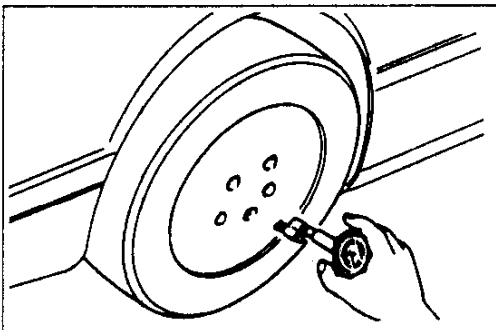

37U0QX-004

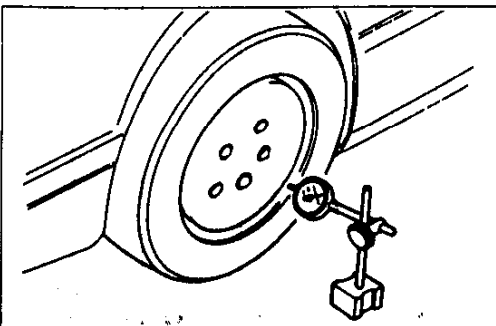

37U0QX-005

INSPECTION/ADJUSTMENT

Check the following and adjust or replace as necessary.

1. Air pressure.
Check the air pressure of all tires, including the spare tire, by using an air pressure gauge.

Air pressure

Standard tire: 220 kPa {2.2 kgf/cm², 32 psi}

**Temporary spare tire: 415 kPa
{4.2 kgf/cm², 60 psi}**

Caution

- **The air pressure must be measured when the tires are cold.**

2. Wheel runout.
Set the probe of a dial indicator against the wheel, and turn the wheel one full revolution.

Wheel runout

Horizontal: 2.0 mm {0.079 in} max.

Vertical: 1.5 mm {0.059 in} max.

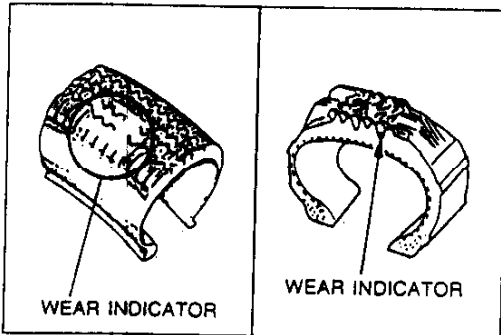

37U0QX-006

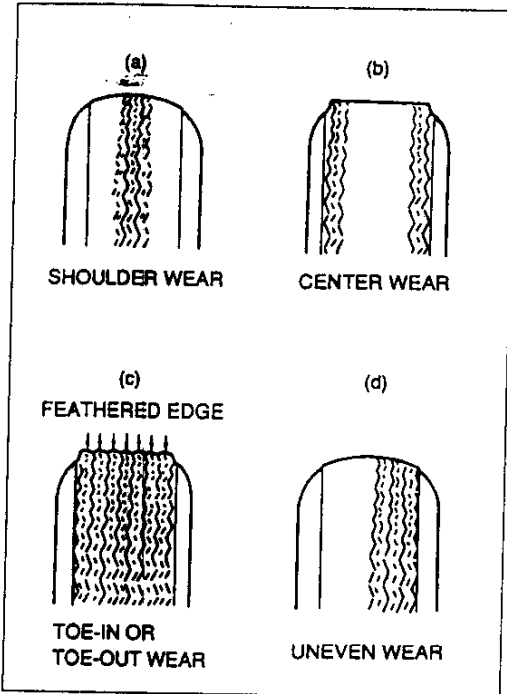

29U0QX-009

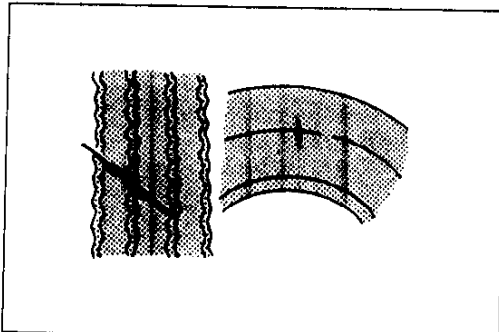

29U0QX-010

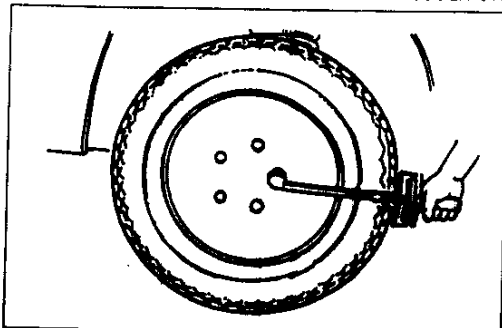

37U0QX-007

3. Tire wear.

Specifications

Remaining tread

Ordinary tires: 1.6 mm {0.063 in} min.

(Tire should be replaced if wear indicators are exposed.)

Snow tires: 50% of tread

(Tire should be replaced if wear indicators are exposed.)

Troubleshooting guide

Abnormal tire wear patterns as shown in the illustration can occur. Refer to the chart for the possible causes and actions.

	Possible cause	Action
(a)	<ul style="list-style-type: none"> ● Underinflation (both sides worn) ● Incorrect camber (one side worn) ● Hard cornering ● Lack of rotation 	<ul style="list-style-type: none"> ● Measure and adjust pressure ● Repair or replace suspension parts ● Reduce speed ● Rotate tires
(b)	<ul style="list-style-type: none"> ● Overinflation ● Lack of rotation 	<ul style="list-style-type: none"> ● Measure and adjust pressure ● Rotate tires
(c)	<ul style="list-style-type: none"> ● Incorrect toe-in 	<ul style="list-style-type: none"> ● Adjust toe-in
(d)	<ul style="list-style-type: none"> ● incorrect camber or caster ● Malfunctioning suspension ● Unbalanced wheel ● Out-of-round brake drum or disc ● Other mechanical conditions ● Lack of rotation 	<ul style="list-style-type: none"> ● Repair or replace suspension parts ● Repair or replace ● Balance or replace ● Correct or replace ● Correct or replace ● Rotate tires

4. Cracks, damage, and foreign matter (such as metal pieces, nails, and stones) in the tire and cracks, deformation, and damage to the wheel.

5. Loose wheel lug nut (s).

6. Air leaking from valve stem.

REMOVAL/INSTALLATION

Tighten the lug nuts to the specified torque in a crisscross fashion.

Tightening torque:

89-117 N-m {9.0-12.0 kgf-m, 66-86 ft-lbf}

Caution

- The wheel-to-hub contact surfaces must be clean.
- Never apply oil to the nuts, studs, or wheels which may cause looseness or seizure of the lug nuts.

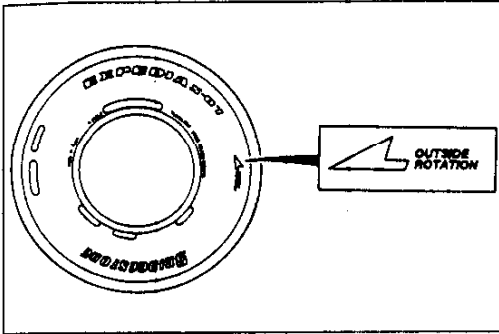

37U0QX-008

Caution

- When mounting the tires, mount them so that the **OUTSIDE** mark faces away from the vehicle (R1).
- Mount the wheels on the vehicle so that the direction mark matches the tire's rotation.

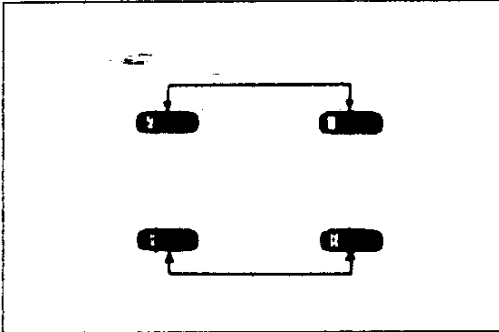

37U0QX-009

TIRE ROTATION

To prolong tire life and assure uniform tire wear, rotate the tires every 6,000 km {3,750 miles}, sooner if irregular wear develops.

Caution

- Do not include "TEMPORARY USE ONLY" spare tire in rotation.
- After rotating the tires, adjust each tire to the specified air pressure. (Refer to page Q-2.)

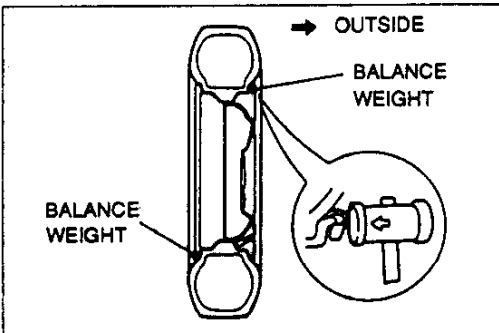

37U0QX-010

WHEEL BALANCE ADJUSTMENT

If a wheel becomes unbalanced or if a tire is replaced or repaired, the wheel must be rebalanced to within specification.

Maximum unbalance (at rim edge): 8g {0.28 oz}

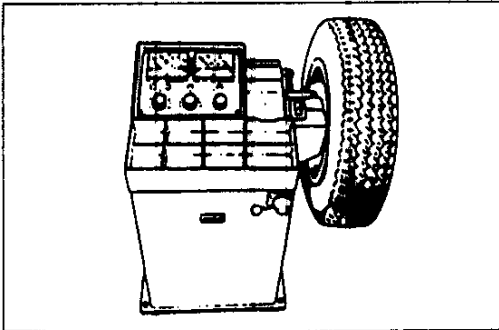

37U0QX-011

Caution

- Do not use more than two balance weights on the inner or outer side of the wheel.
- Individual balance weight: max 60g {2.1 oz}
- If the total weight exceeds 100g {3.5 oz} on one side, rebalance after repositioning the tire on the rim.
- Attach the balance weights tightly to the wheel.
- Select suitable balance weights for steel or aluminum alloy wheels.
- Do not use an on-car balancer for the rear wheels; it may cause transmission damage. (AT)

1

2

3

4

5

6

7

